

# INSTRUCTIONS - Thermostat controlled electrical heater with flow switch

**Water heater for hot tubs, jacuzzis and spas.**

**Package contains:**

The product consists of 1x heaters with thermostat, flow switch and overheating protection and threaded nut connection suitable for glue fixing to 50 mm pipe or hose.

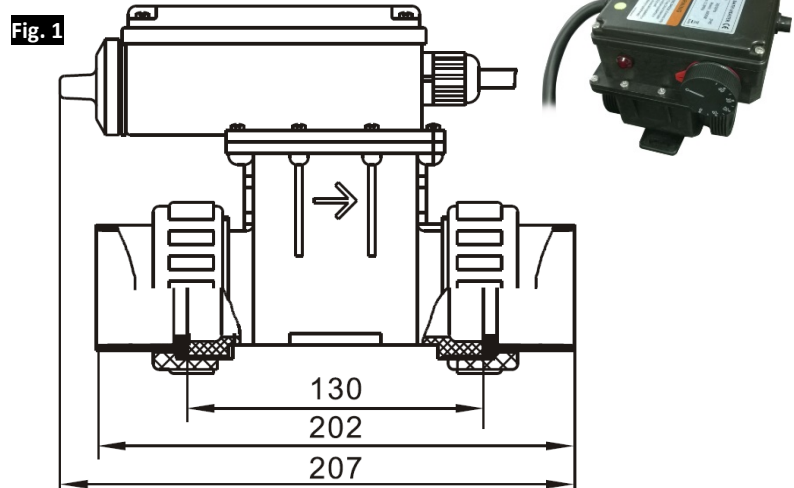
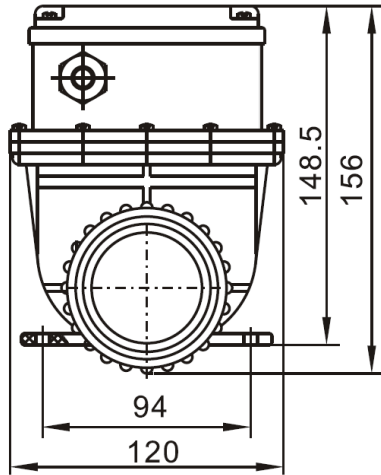

**Specifications:**

**Model: SD-H20**

Rated power: 2000 W  
 Voltage: AC 220-240 V, 50/60 Hz  
 Amps: 8.9 A  
 Max Pressure: 3, 5 Bar (0.035Mpa)  
 Protection class IP45

**Model: SD-H30**

Rated power: 3000 W  
 Voltage: AC 220-240 V, 50/60 HZ  
 Amps: 13.6 A  
 Max pressure : 3,5 Bar (0.035Mpa)  
 Protection class IP45

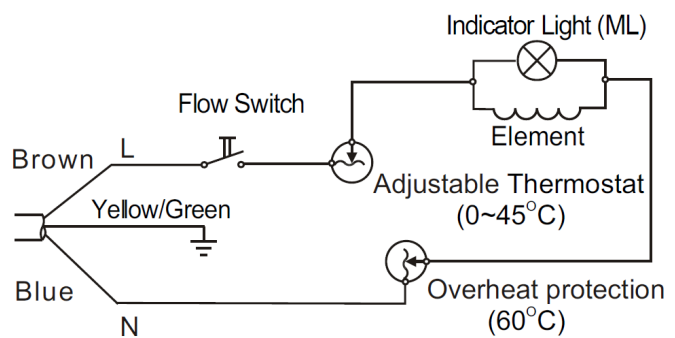

**Note** The electric heater is delivered without plug on the cord. Installation shall done by an authorized electrician.

- L1**            **230V**
- T1**            **Thermostat**
- T2**            **Overheating protection**
- FS**            **Flow switch**
- MS**            **Micro switch**
- ML**            **Indicator light**

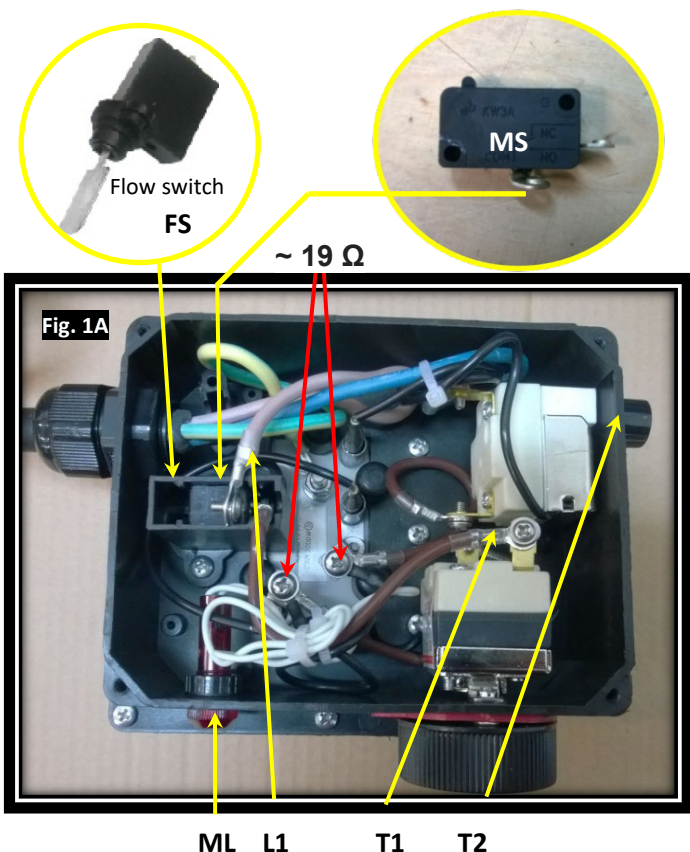

ML L1 T1 T2

## **SAFETY PRECAUTIONS**

### **WARNING!**

- Check that the heater is whole and undamaged on receiving it.
- Read the technical specifications before installing the heater.
- Read the user instructions before installing and using the heater.
- The heater is designed for heating and maintaining water temperature in hot tubs, jacuzzis, spas and smaller pools.
- All electrical work must be carried out by a qualified electrician.
- The heater must be connected to a grounded power source with ground fault switch.
- The heater must not be covered when it is in operation.
- When cleaning the heater or other action that requires opening it, always switch off the power beforehand.
- Never use the heater if the power cable is damaged. In this case, leave the heater to a qualified electrician or the dealer for inspection and repair.
- The heater can be used indoors and outdoors. It's enclosure class is rated IP45 and is protected against touch and penetrating objects with at least 1 mm diameter. It is also spray proof against water but we recommend keeping it in a protected area out of reach of children or other inexperienced persons without the necessary product understanding.
- In areas with hard water (high calcium content) it is necessary to decalcify the heater periodically as lime coatings can reduce the effect and also destroy the heating element

### **Feature Description:**

The heater's specification is shown on the label that is located on top of the heater. The heater has a built-in flow switch with a micro switch. In order for the microcontroller to supply power to the thermostat, a circulation pump with sufficient water flow (at least 3600 l / h) must be used. If the water temperature is lower than that set by the thermostat, it will pass on to the electrical heater in the heater when the flow switch activates the microcontroller. In case the flow is insufficient or the pump stops, the heater will turn off. When using a filter system, it is important to check that the filter media is clean as otherwise it reduces water flow that may affect the flow monitor function so that the power is not switched on and thus does not heat the water.

**Fig. 2**

**Installed on inlet side**

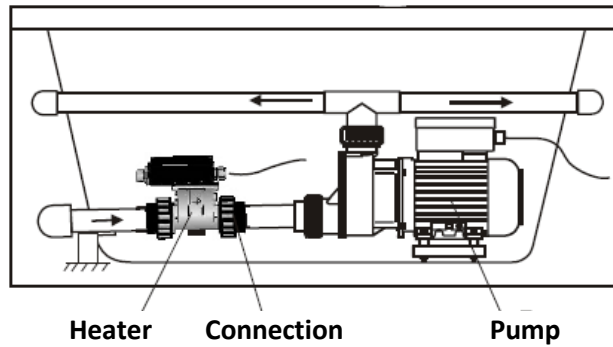

**Installed on outlet side**

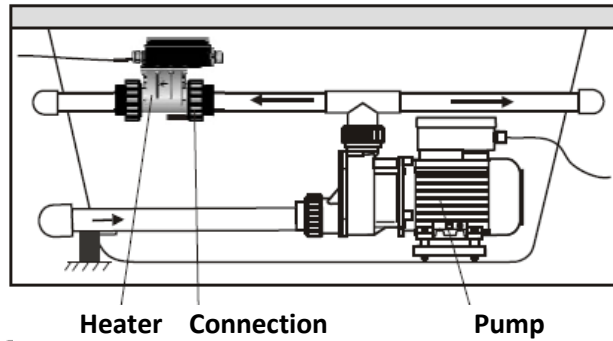

## INSTALLATION

The water heater must be connected to a circulation system with a pump that gives a flow rate of at least 3600 liters / hour. On the heater there are arrows that show in which direction it should be mounted. Arrows should always turn in the direction of the water flow.

1. The heater should be mounted horizontally or vertically.
2. The heater can be connected either to the water outlet or outlet of the installation (**fig.2**)
3. For connection to the heater's nut connections, use a PVC hose or pipe (**fig.2,3**). By default, the connection has 50 mm internal diameter, but it can also be reduced to 32 mm. Then a reduction that is not included in the standard package is required. Ask for your seller.
4. Glue the tube or hose with PVC glue. Clean the surfaces to be glued properly before.
5. Before gluing, tighten the nuts in the heater from both sides. Apply glue on the inside of the nut as well as to the hose / tube and join them. This will make the distance correct.
6. The heater cover should face upwards after assembly.
7. Class 1 installations, as this heater is, must be connected to a solid power source.
8. Example of installation to sand filter system (**Fig. 3**)

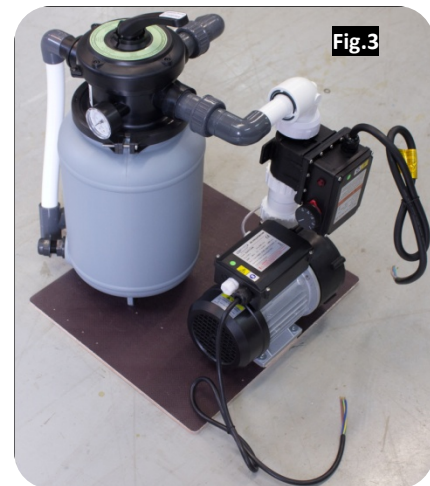

## POWER CONNECTION

- Connect the heater to a power source with ground fault switch. The correct power source for the heater is indicated on the heater label.
- Any extension cable should be in accordance with national standards and have the same dimension as cable for power source. For 2 kW, 3 x 1.5 mm<sup>2</sup> and 3 kW, the cable connection area must be 3 x 2.5 mm<sup>2</sup>.
- It is very important to ensure that the cable is connected correctly.
- When the installation is complete, the ground fault switch must be tested before using the heater.

## SAFETY FEATURES

- The water heater has a built-in flow switch with micro switch connected to the 230V line that only works when the pump is running and the water circulates through the heater. The minimum water flow for the pump should be 3600 liters / hour.
- The water heater has overheat protection that automatically turns off the heater if the water temperature exceeds 60 ° C. If the protection fails, unscrew the nut, which covers a red plastic stick and push the pin. **See fig. 1A, T2, page 1.** If it feels slow and a click is heard, it had released. This can happen if, for example the pump is taking air and there isn't constant or sufficient water flow through the heater. For example. If the water level is too low or the filter is not cleaned properly.

## BEFORE STARTING THE HEATER

- Check that the arrow symbol on the lower part of the heater points in the direction of the water flow. If the heater is placed on the suction side of the pump, the arrow symbol should point to the pump and if it is positioned after the pump, it should point away from the pump. Power source for the heater is indicated on the heater label.
- Also check that there are no leak from couplings and hoses.

## START THE HEATER

Start the pump and heater only when you are sure that the power, hoses and connections are properly installed. Adjust the thermostat to the desired temperature. Note that labels are for guidance only. Temperature differential is  $\pm 3^{\circ}\text{C}$  at set stop temperature and start  $4^{\circ}\text{C} \pm 2^{\circ}\text{C}$  from stop temperature. **NOTE!** Avoid resetting the thermostat when the desired heat is reached as it may cause large temperature variations to occur. Expect a heating rate of 2.5 degrees per hour for 1000 liters of water.

## MAINTENANCE

The heater does not require any special maintenance. If not used for a long time, we recommend opening connections to allow water to drain and not cause bacterial growth. If there is any damage to the cable, replace it. Contact a qualified professional for inspection, repair or adjustment.

## DISPOSAL

This product must not be disposed of as ordinary household waste. It must be submitted to an approved waste disposal site for electrical products.

## WARRANTY

The warranty period for the product is 2 years, and applies to material, construction and / or fabrication defects that cause the product to not function properly. In case of complaint, the seller must be contacted first and a valid purchase receipt must be available. Defective parts are repaired or replaced.

The warranty does not apply to transport damage, for damage caused by improper use, subsequent faults caused

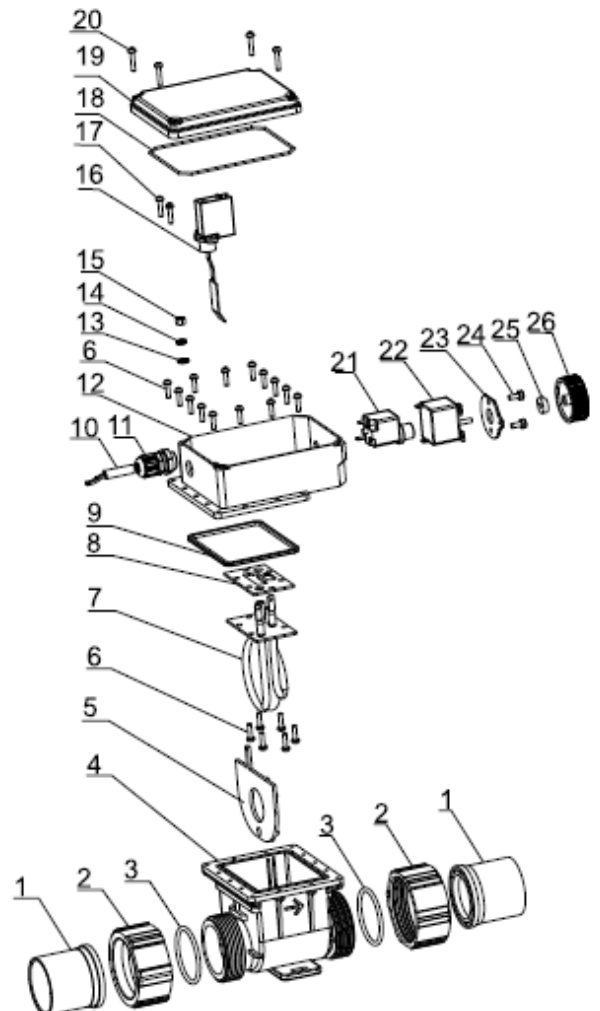

by this, defects in the installation performed by the buyer / user or anybody hired, modifications of the product, weather or electrical phenomenons beyond our control.

Any freezing damage that occurs after delivery is not covered by the warranty.

It is always the responsibility of the user to take measures to prevent freezing damage. This applies both before and after installation.

The seller cannot be held liable for direct or indirect damage, consequential damages or losses to the buyer.

**If you have questions about this product or in case of complaint, contact SpaDealers, [info@spadealers.fi](mailto:info@spadealers.fi)**

NO.	Name
1	Tie
2	Tie-in nut
3	O-Ring
4	Base
5	Baffle plate
6	Cross recessed pan headt apping screws
7	Electric heating tube component
8	Sealing pad
9	Terminal box
10	Cable
11	Cordgrip
12	Terminal Box
13	Washer
14	External teeth lock washers
15	Hex Nut
16	Flow switch
17	Cross recessed pan headt apping screws
18	O-Ring

NO.	Name
19	Box cover
20	Cross recessed pan headt apping screws
21	Manual reset thermostat
22	May thermostat controller
23	Scale signage
24	Cross recessed pan headt apping screws
25	Thermostat pad
26	Thermostat knob